

MATERIAL:	1035 STEEL OR BETTER
HARDNESS:	38-45HRC THROUGH HARDENED
MECH. & PHYSICAL PROPERTIES	PER ASTM F-436
HEADMARK:	"NT" & DIAMETER + "S" (SEE BELOW)
FINISH:	ZINC YELLOW CR+6

PRODUCT IS NOT DRAWN TO SCALE

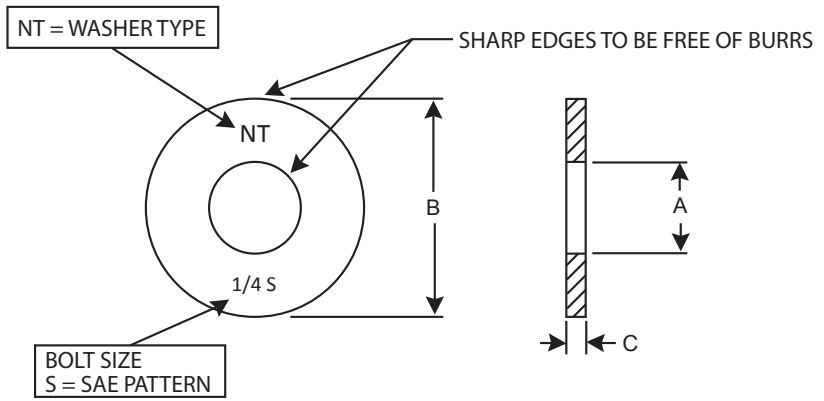

Nom Bolt Size	Part Number	A			B			C	
		Inside Dia			Outside Dia			Thickness	
		Basic	+TOL	-TOL	Basic	+TOL	-TOL	Max	Min
1/4	25SNT8Y	0.281	0.015	0.005	0.625	0.015	0.005	0.065	0.055
5/16	31SNT8Y	0.344	0.015	0.005	0.688	0.015	0.007	0.065	0.055
3/8	37SNT8Y	0.406	0.015	0.005	0.812	0.015	0.007	0.065	0.055
7/16	43SNT8Y	0.469	0.015	0.005	0.921	0.015	0.007	0.065	0.055
1/2	50SNT8Y	0.531	0.015	0.005	1.062	0.030	0.007	0.116	0.100
9/16	56SNT8Y	0.594	0.015	0.005	1.156	0.030	0.007	0.116	0.100
5/8	62SNT8Y	0.656	0.030	0.007	1.312	0.030	0.007	0.138	0.122
3/4	75SNT8Y	0.812	0.030	0.007	1.469	0.030	0.007	0.138	0.122
7/8	87SNT8Y	0.938	0.030	0.007	1.750	0.030	0.007	0.152	0.136
1	100SNT8Y	1.062	0.030	0.007	2.000	0.030	0.007	0.160	0.136

DESCRIPTION:
SAE PATTERN "NT" HARDENED FLAT WASHERS



NATIONAL THREADED FASTENERS, LTD. CLAIMS ALL PROPRIETARY RIGHTS TO THIS DRAWING AND THE INFORMATION IT CONTAINS. THIS MATERIAL IS CONFIDENTIAL. DISCLOSURE, REPRODUCTION, AND MANUFACTURING IS STRICTLY PROHIBITED WITHOUT THE EXPRESS WRITTEN PERMISSION OF NATIONAL THREADED FASTENERS, LTD. ALL RIGHTS OF DESIGN OR INVENTION ARE RESERVED.

THIS DRAWING IS FOR REFERENCE ONLY AND SHOULD NOT BE USED DURING THE MANUFACTURING PROCESS.

UNITS: INCH	PRODUCT SERIES: SNT8Y	DRAWN: AGRAHAM	DATE: 1/9/15	REV: A
--------------------	------------------------------	-----------------------	---------------------	---------------